

B R O O M F I E L D

100

# Multi-Speed Coil Winding Machine

## SPECIFICATIONS

The **Broomfield 100** coil winding machine provides for winding up to a 10" (254mm) diameter coil. Four speed ranges allow for various winding speeds and torques.

### Features & Benefits:

- Four spindle speed ranges with variable speed within each range. (Maximum speed 5250 RPM)
- Welded steel construction for superior strength.
- Electrically actuated brake for positive stopping.
- Electronic wire guide traverse: Two precision layering styles are provided; Parallel and Spiral.
- Set-up time is minimized by use of electronic controls for setting wire pitch and stopping at the desired turns count. The operator only needs to enter this data and set the winding width stops.
- Easily adaptable for winding single or multiple coils.
- Optional MP-4 control with greater programming power.



B R O O M F I E L D

100

# Multi-Speed Coil Winding Machine

**Motor Equipment:** 1 HP (0.746Kw) AC Vector motor and drive with foot controlled variable speed.

**Faceplate:** 8" (203mm) diameter.

**Reduction:** Belt and pulley.

**Spindle Speeds & Corresponding Torques:**

0-875 rpm	72 in.-lbs.	(8.1 Nm)
0-1750 rpm	36 in.-lbs.	(4.0 Nm)
0-3500 rpm	18 in.-lbs.	(2.0 Nm)
0-5250 rpm	12 in.-lbs.	(1.36 Nm)

**Power Requirement: Electrical:** 220 V, three phase, 15 amps. Other voltages available.

**Spindle Rotation:** Either direction can be selected by a switch on the control panel.

**Spindle Center Height:** 37" (940mm) from the floor.

**Brake:** Electronically actuated brake operated by removing foot from variable speed control, by programmed turns count or by emergency stop button.

**Tailstock:** Mounted on precision ways to allow positioning anywhere along winding axis. 2" (50.8mm) quill travel with quick toggle action. 60° spring loaded live center.

**Maximum Distance Between Centers:** 24" (610mm)

**Maximum Swing Diameter:** 12" (304mm)

**Machine Control:** S-50 winding controller with 50 programmable stops, 7 program capacity, parallel and spiral layering, pitch increment .0001" (.003mm) and end stops to define winding width. (See S-50 page for details)

**Weight:** 1000 lbs. (454Kg)

**Options:**

- Broomfield MP-4 coil winding controller automatically coordinates coil winding functions and provides for program storage. (See MP-4 page for details)
- Multi-wire guide assembly.
- Automatic run.
- Longer machine length.
- Lower speed ranges.
- Custom modifications for special applications.
- Winding forms and toolings.
- Winding area guard.

100 Model

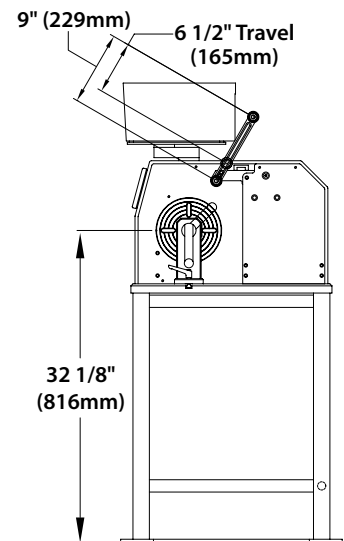
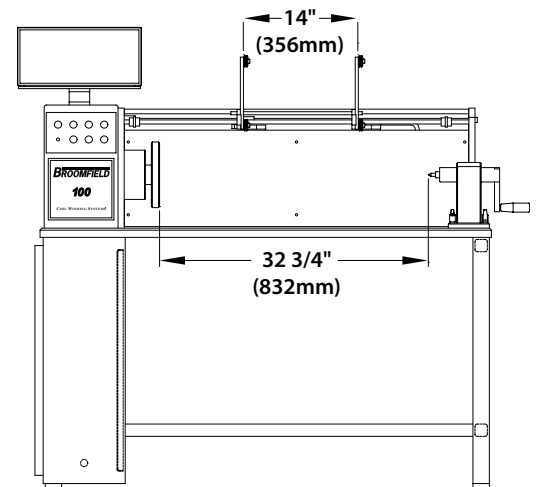

P.O. BOX 157  
113 STILL RIVER ROAD  
BOLTON, MA 01740-0157 USA  
P: 1-978-779-6600  
F: 1-978-779-2954  
E: info@broomfieldusa.com

WWW.BROOMFIELDUSA.COM

**BROOMFIELD**