

B R O O M F I E L D

W F - 5 0

WF-50 Wire Flattening Machine

SPECIFICATIONS

The **Broomfield WF-50** Wire Flattener can be used in-line with a coil winding machine to flatten round copper or aluminum wire. Because the unit is totally self-contained, it can be installed with any existing winding machine. A dancer control coordinates the wire flattening speed to the wire winding speed and provides consistent wire tension. This stand-alone system requires no connections to the winder or wire dereeler.

Since round wire is typically less expensive than shaped conductor, significant savings may be realized if designs requiring square or rectangular wire are wound with round wire but processed through the Broomfield Wire Flattener during winding.

It is generally held that most small to medium diameter film coated magnet wire can be flattened to approximately 60% of its original thickness without harming the insulation. The Broomfield WF-50 Wire Flattener can produce flattened conductor within its flattening range and is motor driven to have sufficient power and speed to keep up with high winding speeds.

Features & Benefits:

- Requires no integration with a winding machine.
- Heavy-Duty welded steel construction.
- Easy to change flattening size.
- Fine adjustment for more precision sizing.
- Consistent wire tension.
- Accommodates winding machine acceleration and deceleration.
- Dancer carriage accumulates wire and reduces negative effects from high speed winding on rectangular coils.



B R O O M F I E L D

WF-50

WF-50 Wire Flattening Machine

Wire Range Handled: 26 AWG (.017") (.43mm) to 10 AWG (.1039") (2.64mm).

Flattening Range: .010" (0.25mm) to .145" (3.68mm).

Wire Processing Speed: Variable up to 2,000 ft/min. (10.1m/sec.).

Drive System: 15 HP (11.19Kw) AC Motor.

Input Requirements: Electrical: 460 volts, three phase, 30amps.
Other voltages available.

Air: 80psi (5.5 Bars).

Weight: 950 lbs. (431 Kg)

Options:

- Special input side wire path pulley arrangements to allow for various wire dereeler positions.
- Wire breakage output to signal operator or stop wind.
- Other input voltages.
- Larger base frame to incorporate (2) complete systems in common base for space savings when flattening (2) wires simultaneously.

WF-50 Model

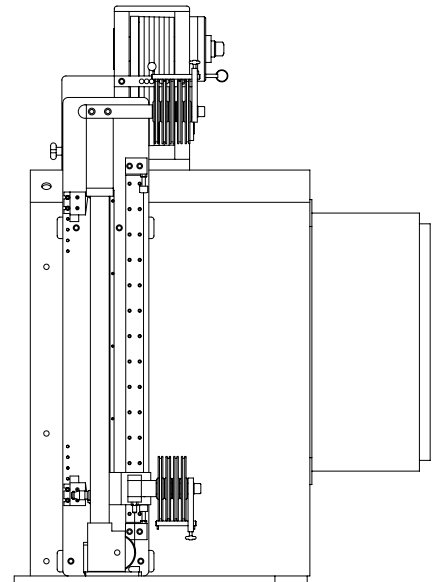
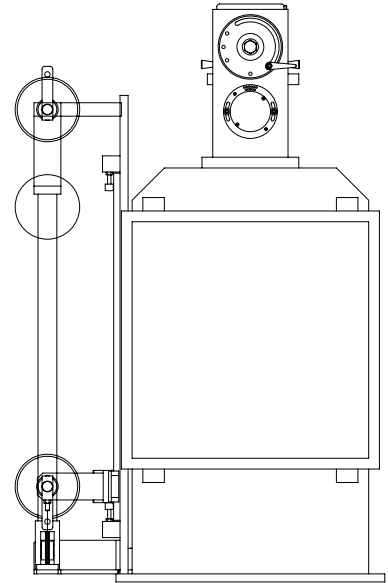

P.O. BOX 157
113 STILL RIVER ROAD
BOLTON, MA 01740-0157 USA
P: 1-978-779-6600
F: 1-978-779-2954
E: info@broomfieldusa.com

WWW.BROOMFIELDUSA.COM

BROOMFIELD